

resideo

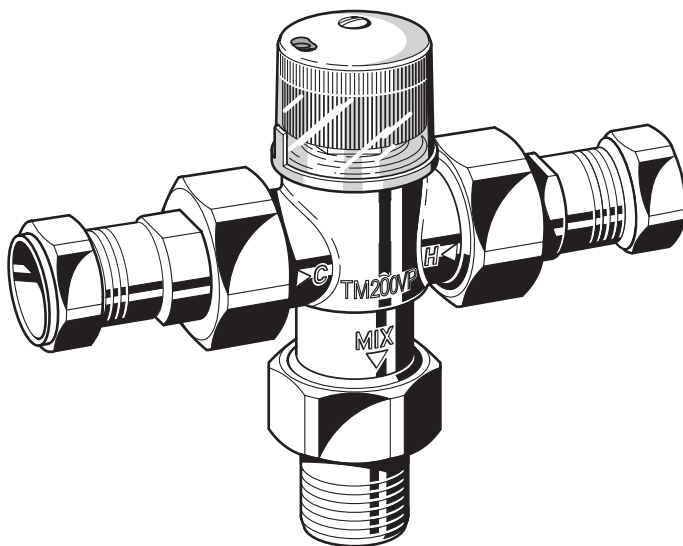

Braukmann TM200VP



R32347807-001 Rev.A

Keep instructions for later use!

Thermostatic Mixing Valve

1. Safety Guidelines

- Follow the installation instructions.
- Use the appliance
 - according to its intended use
 - in good condition
 - with due regard to safety and risk of danger.
- Note that the appliance is exclusively for use in the applications detailed in these installation instructions. Any other use will not be considered to comply with requirements and would invalidate the warranty.
- Please take note that any assembly, commissioning, servicing and adjustment work may only be carried out by authorized persons.
- Immediately rectify any malfunctions which may influence safety.

2. Application

The Resideo TM200VP TMV3 Approved thermostatic mixing valve has been specially designed to meet the NHS Model Engineering Specification D 08 to reduce the risk of emitting water at an unsafe temperature.

Valves operating outside the conditions shown in the table below cannot be guaranteed to operate as TMV 3 valves.

Table 1: Conditions for normal use

Operating pressure range	High pressure	Low pressure
Maximum static pressure [bar]	10	10
Flow pressure, hot & cold [bar]	1 to 5	0.2 to 1
Hot supply temperature [°C]	52 - 65	52 - 65
Cold supply temperature [°C]	5 - 20	5 - 20

Thermostatic mixing valves are required to meet specific performance criteria dependent on application.

Table 2: Mixed water temperature

	Application	Mixed water temperature (at point of discharge [°C])
B	Bidet	38 max.
S	Shower	41 max.
W	Washbasin	41 max.
T44	Bath (44°C fill)	44 max.

Table 3: Suitable applications

	suitable for application on
TM200VP 3/4E (15mm)	HP-W, LP-W, LP-B, HP-B, LP-S, HP-S, HP-T44
TM200VP 3/4H (22mm)	HP-W, LP-W, LP-B, HP-B, LP-S, HP-S, HP-T44

The TM200VP can be fitted to a single outlet or to several outlets, provided that both the water supply pressures and flow rates are adequate.

- i** To comply with health guidelines, a thermostatic mixing valve should be no further than two metres from any outlet it is supplying.

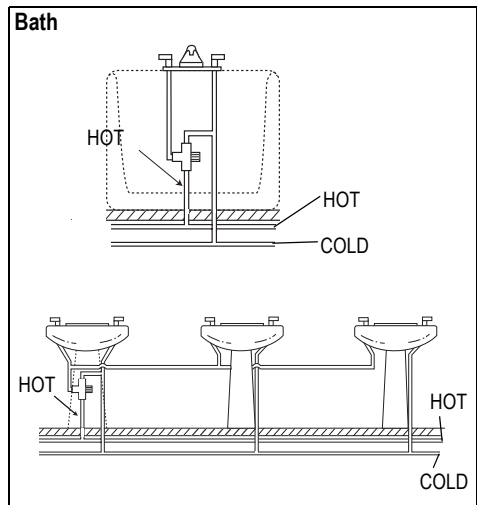

Diagram 1

3. Specification

Table 4: Specifications

Maximum working pressure	10 bar
Maximum hot inlet temperature	90°C
Supply pressure to both Hot and Cold inlets should be within the following range, but not exceed the differential pressure stated below	
High pressure systems	0.5 - 5.0 bar
Low pressure systems	0.1 - 1.0 bar
Maximum differential pressure between Hot and Cold should not exceed the following	
High pressure systems	2.0Δ- bar
Low pressure systems	0.4Δ- bar
Mixed temperature setting range	35°C-46°C
Minimum temperature between hot supply and mix to ensure safety shut-off requirement	10°C
Valve body material	
Dezincification resistant chrome plated brass	
Materials = WRAS approved for use with wholesome water	
Approvals= Buildcert approved as meeting the NHS Model Engineering Specification D 08 - certificate number BC308/0108	

4. Flow rate chart

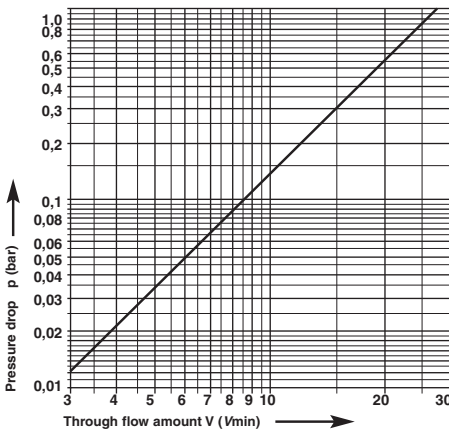





5. Safety shut-off feature

The TM200VP will automatically close off the mixed water flow in the event of either hot or cold water supply failure when installed in accordance with these installation instructions.

-  After safety shut-off shutdown has occurred, and the mixing valve has cooled down, very low flow may occur. This is normal and is not cause for alarm.

6. Installation

6.1 Safety guidelines for installation

-  Jointing compound will cause damage to the internals of the mixing valve and prevent the check valves from functioning correctly.
Therefore, jointing compound must not be used on the connections and could invalidate the warranty if used.
Use of jointing compounds in other parts of the installation should be avoided or flushed out before fitting the TM200VP.
-  It is preferable for the TM200VP to be installed with balanced dynamic pressure. However, control will also remain within the specified limits when supply pressures are different, provided that under flow conditions the pressure differential between the supplies remain within the stated specification. The installer must take precautions to ensure this.
-  Failure to observe these instructions may lead to a potential failure or incorrect operation of the valve.
-  It is strongly recommended that the pipework is flushed before installing the mixing valve.
 - Grit, flux and other debris will adversely affect the performance of TM200VP.
 - No claim for malfunction will be considered if adequate protection against dirt ingress is not provided.
-  If there is any doubt then a strainer (e.g. Resideo FY32) should be fitted upstream of the TM200VP and on both hot and cold supplies.

6.2 Installation Guidelines

These instructions should be followed to ensure a trouble free installation. The installer should make sure that the installation complies with the requirements of the Water Regulations and any other relevant regulations.

- Before installing a TM200VP, check water flow rates, supply temperatures and dynamic pressures at all hot and cold taps. A calibrated jug or vessel of known volume and a watch with a second hand can be used for water flow measurements. Alternatively a water flow gauge can be used.
- Due account should be taken of multiple demand, for example, the simultaneous use of two or more taps to ensure adequate hot and cold flow rates to the mixing valve is maintained even when the outlets are turned on.
- When installing with unit with plastic pipe, an appropriate insert should be used according to the pipe manufacturer's recommendation.
- Sufficient consideration should be given to the support of the unit, particularly if installing with plastic pipe. Where necessary, it is recommended to use copper pipe on at least one leg (the valve outlet to the tap may be the most suitable).
- The TM200VP has been designed to slow down the build up of calcium within the valve body. However, in known hard water areas, the use of a water treatment device should be considered to promote trouble free operation of the controls and fittings.
- It is preferable for the TM200VP to be installed with balanced dynamic pressure. However, control will also remain within the specified limits when supply pressures are different provided that under flow conditions the pressure differential between supplies is within the stated specification.
- The TM200VP can be installed in any orientation including vertical or horizontal pipework.
- It is recommended that isolation/service valves are installed in the supply pipework adjacent to the TM200VP to facilitate servicing of the valve.
- The TM200VP is provided with 15mm or 22mm compression fitting and flanged connectors on all three ports. This enables the valve to be fitted to an existing system without straining the pipework and also assists with the servicing of the mixing valve.

6.3 Installation

1. The TM200VP should be connected in the hot water supply pipe with the flow in the direction of the arrows stamped on the body, '+' = HOT, '-' = COLD and MIX to hot tap(s).
2. The integral check valves supplied within the tail-pieces of the TM200VP must be fitted to the hot and cold inlet ports, as shown in diagram 2. This is to prevent cross circulation between hot and cold pipes and they should not be removed under any circumstances.

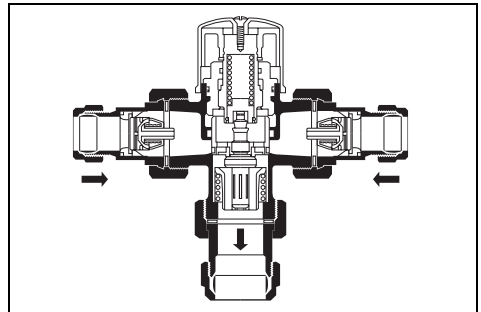

Diagram 2

7. Setting the TM200VP

The valve is set by turning the green control knob clockwise to reduce the mixed water temperature and anti-clockwise to increase the mixed temperature.

The valve has a single turn through approximately 360°, with a central control band from 35°C to 46°C.

The hot tap should be left to stabilise before final setting to ensure correct adjustment.

For convenience typical settings are marked on the green control knob.

These settings will be accurate when dynamic hot and cold supply pressures are equal. They will vary slightly from the indicated figure when hot and cold supply pressures are different and should be used as a guide only. The mixed water temperature should be set at the temperature required for a particular application (See Table 2).

8. Locking the setting

Once the correct setting has been achieved it can be locked in position by placing the clear cap over the control knob ensuring the notch in the clear cap and lug on the valve are engaged (see diagram 3). The cap is then secured in place with the screw provided. The actual set point temperature can be viewed through the clear window as shown on the locking cap in diagram 3.

The TM200VP is now ready for use.

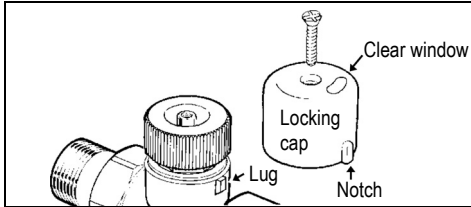

Diagram 3

9. A typical example

The example shown in diagram 4 below shows a typical system with mains pressure cold feed and low pressure tank fed hot water installation. Under these conditions the hot and cold water is separate and therefore differences in fluctuations in hot and cold flow rates and pressures whilst being a nuisance are not that important. Once mixing valve(s) are fitted as shown in diagram 5 to give a blended hot water temperature, the hot and cold systems are connected and steps must be taken to ensure that the supply pressures are kept within the specified differential. In diagram 5 this has been achieved by fitting a pressure reducing valve (for example, a Resideo D05 pressure reducing valve) on the common cold inlet. This not only gives improved performance from the mixing valves but also the system in general. In addition, pressure reducing valves help reduce the overall water consumption.

1. If a new water main is fitted, or work is carried out to the old water main then a strainer should be fitted immediately after the stop tap to prevent debris from entering the mixing valves. If work is carried out to an existing system please refer to the section on installation. If there is any doubt, then a strainer should be fitted.

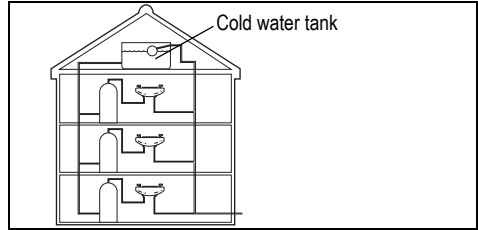

Diagram 4

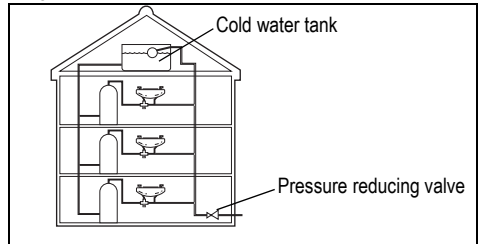

Diagram 5

2. Because pressures vary due to head loss between upper and lower floors as well as pipework layout and sizing, fitting pressure reducing valves in higher pressure zones will reduce the flow from outlets in those areas minimising the risk of starving flow in other lower pressure zones.
3. The mixing valves are normally fitted one per hot outlet. The TM200VP can be fitted to serve several outlets provided that both the water supply pressures and mixed flow rates are adequate. To comply with health regulations, no tap should be more than two metres away from the mixing valve.

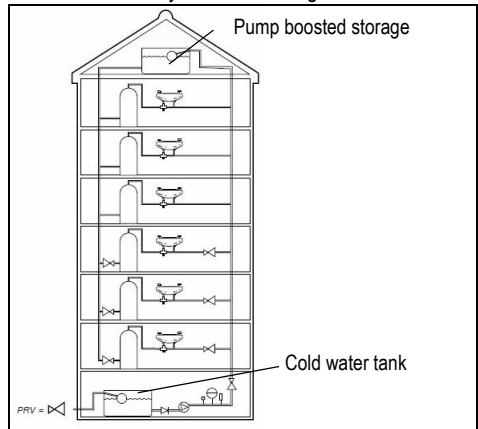



Diagram 6 Multi-storey pump-boostered with high and low storage

10. Commissioning the TM200VP

1. Check that the designation of the TM200VP matches the intended application (Table 2), that the supply pressures are within the range of operating pressures and that the supply temperatures are within the range permitted for the valve from guidance information on the prevention of legionella.
2. Adjust the temperature of the mixed water following the instructions given in 'Setting the TM200VP', and the requirements of the application
 - o record the temperature of the hot and cold supplies
 - o record the temperature of the mixed water at the smallest and largest draw-off flow rates
 - o turn off the cold water supply to TM200VP and record the mixed water temperature and the maximum temperature achieved

 The values should not be greater than 2°C of the nominal set point shown in Table 2.

11. Servicing

11.1 General information

Most domestic water supplies contain calcium which will separate out when the water is heated in a system.

The degree and speed of scaling depends, amongst other factors, on water flow rates, system design, the degree of hardness of the water and the temperature to which it is heated.

Over a period, scale may form within the valve, particularly at the hot inlet where the water is hottest and this may eventually prevent one or more ports from closing fully and thereby impair the temperature control.

Descaling of the mixing valve then becomes necessary.

Because circumstances differ between installations, it is not possible to give a definitive water hardness level which will affect the mixing valve within a certain time period.

Simple scale protection of the incoming water supply on any system will always provide benefits in extending the efficient operating life of thermostatic mixing valves and other fittings before service is required.

 Scale protection is essential in applications where water is particularly hard.

If purpose made measuring equipment is not readily available, a good guide to hardness can be established by checking site experience with speed of scale build up in kettles or coffee machines.

11.2 Servicing

 It is recommended that the mixing valves are inspected on a regular basis, at least annually, or more frequently if performance is impaired, to ensure they are working correctly and that dirt ingress into the system does not cause a loss in performance of the mixing valve.

 Please note that during servicing the valve piston should be greased with an approved (WRAS) silicon lubricant.

 If required, a Resideo service kit is available for cartridge replacement.

1. Prior to servicing the TM200VP, the mixed water temperature must be recorded. Should the temperature be 2°C greater than the nominal setting the following should be checked before dismantling the valve
 - o Check strainers are clean
 - o Ensure check valves are in good working order
 - o Check isolating valves are fully open
2. If these checks are satisfactory then the Resideo service kit is available for cartridge replacement (separate instructions in the service kit detail this procedure). After servicing the commissioning procedure detailed in point 10 under 'Commissioning the TM200VP' should be followed.

12. In-service testing

Following commissioning, in-service tests (as shown in 'Commissioning the TM200VP') should be carried out at 6-8 weeks and 12-15 weeks.

1. If no significant changes (i.e. $\leq 1K$) occur in either test, a further inservice test should be carried out at 24 to 28 weeks after commissioning.
2. If small changes (i.e. 1 to 2K) occur in one test necessitating adjustment, a further in-service test should be carried out at 24 to 28 weeks after commissioning.
3. If small changes (i.e. 1 to 2K) occur in both tests necessitating adjustment, a further in-service test should be carried out at 18 to 21 weeks after commissioning.
4. If significant changes (i.e. $> 2K$) occur in either test necessitating service work, a further in-service test should be carried out at 18 to 21 weeks after commissioning.



The general principle to be observed after the first 2 or 3 in-service tests is that the intervals of future tests should be set to those which previous tests have shown can be achieved with no more than a small change in mixed water temperature.



resideo

Manufactured for
and on behalf of
Pittway Sàrl, Z.A., La Pièce 4,
1180 Rolle, Switzerland

For more information
homecomfort.resideo.com/europe

Ademco 1 GmbH, Hardhofweg 40,
74821 MOSBACH, GERMANY

Phone: +49 6261 810
Fax: +49 6261 81309