



Braukmann NK295S

Refilling combination
compact construction

APPLICATION

The refilling combination serves automatic filling and refilling from closed heating systems to EN 12828:2014-07.

It can be connected in accordance with EN 1717 permanently with the drinking water supply.

The refilling combination combines a CA type backflow preventer, pressure reducing valve and two ball valves in one appliance.

The refilling combination contains all devices for refilling a heating installation, according to conforming standards.

APPROVALS

- DIN/DVGW approved check valve

SPECIAL FEATURES

- Permanent connection with the drinking water supply in accordance with EN 1717 by hose line or piping is possible
- Triple security - two check valves and a discharge valve separate the backflow preventer into three pressure zones
- Optimal protection of the drinking water supply system
- Pressure reducing valve with inlet pressure balancing - inlet pressure fluctuation does not influence the outlet pressure
- Field-tested, reliable pressure reducing valve
- Outlet pressure adjustable and directly visible on the pressure gauge
- DIN/DVGW approved check valve
- Compact construction
- Low maintenance effort
- Corrosion resistant by use of brass and stainless steel
- Low pressure loss and high flow rate
- Variable connection options to the heating system
- Meets KTW recommendations for drinking water

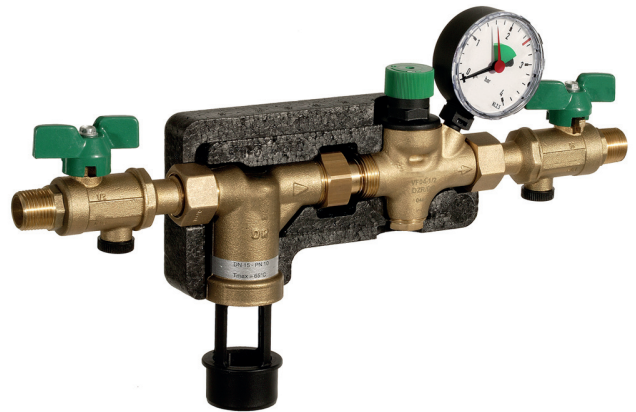

TECHNICAL DATA

Media	
Medium:	Water without inhibitors
Connections/Sizes	
Connection sizes:	HT40
Connection size discharge:	1/2" AG
Pressure values	
Inlet pressure:	1.5 - 10 bar
Outlet pressure:	1.5 - 6 bar
Operating temperatures	
Max. operating temperature medium:	65 °C
Specifications	
Liquid category backflow preventer BA:	3 (slightly toxic materials)
Installation position:	horizontal pipework with discharge connection directed downwards

CONSTRUCTION

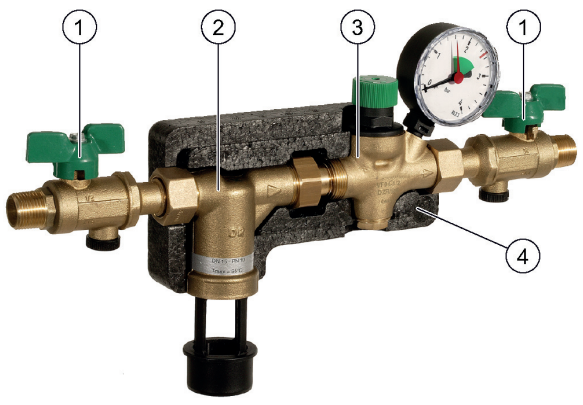
Overview	Components	Materials
	1 Shut-off valve, up- and downstream	Dezincification-resistant brass
	2 Complete backflow preventer with discharge connection, valve cartridge (incl. integrated check valve and discharge valve, upstream), integrated strainer upstream (mesh size approx. 0.5 mm) and check valve downstream	Discharge connection, valve cartridge, valve insert and spring bonnet in high-grade synthetic material
	Complete pressure reducing valve with valve insert (incl. diaphragm and valve seat), spring bonnet (incl. adjustment screw), adjustment spring and pressure gauge	
	3 Isolation shell	EPP
	Not depicted components:	
Seals	NBR, EPDM	
Diaphragm	Fibre-reinforced NBR	
Check valve	High-grade synthetic material	
Adjustment spring	Spring steel	

METHOD OF OPERATION

The refilling combination serves automatic filling and refilling from closed heating systems to EN 12828:2014-07.

The refilling combination combines backflow preventer, pressure reducing valve and ball valves in one appliance. The backflow preventer is a safety device in accordance with EN 1717 to protect the quality of drinking water against back pressure, backflow and back syphonage of non-drinking water from plants and connected equipment. The backflow preventer is separated in three chambers (inlet, middle and outlet chamber).

If no water is drawn from the downstream system, the backflow preventer is in normal position. The up- and downstream check valves and the discharge valve are closed.

If water is drawn from the downstream system, the backflow preventer is in flow position. The check valves up- and downstream are opened and the discharge valve is closed. The backflow preventer changes to shut-off position (back pressure) if the differential pressure between middle- and inlet chamber falls under 0.14 bar. The check valves are closed and the discharge valve is opened.

There is no possibility to control the safety function by measuring.

The pressure reducing valve reduces the inlet pressure to the desired set-pressure on the outlet side.

The pressure reducing valve works according to the force comparison principle. The force of a diaphragm operates against the spring force of the regulating valve. If the outlet pressure and therefore diaphragm force fall because water is

drawn, then the greater force of the spring causes the valve to open. The outlet pressure then increases until the forces between the diaphragm and the spring are equal again.

The inlet pressure has no influence in either opening or closing of the valve. Because of this, inlet pressure fluctuation does not influence the outlet pressure, thus providing inlet pressure balancing.

The refilling combination can be connected in accordance to EN 1717 constantly by hose line or piping. (KTW-approval for hose line necessary).

In order to prevent an uncontrolled refill of the heating system, the shut-off valve must be closed after the filling procedure.

TRANSPORTATION AND STORAGE

Keep parts in their original packaging and unpack them shortly before use.

The following parameters apply during transportation and storage:

Parameter	Value
Environment:	clean, dry and dust free
Min. ambient temperature:	-15 °C
Max. ambient temperature:	70 °C
Min. ambient relative humidity:	25 % *
Max. ambient relative humidity:	95 % *

*non condensing

INSTALLATION GUIDELINES

Setup requirements

- The installation must take place at the deepest point of the heating system
 - Install in horizontal pipework with discharge connection directed downwards
 - The installation may not take place in areas or ducts where poisonous gases or vapours may be present or where flooding can occur
 - The installation location must be ventilated well
 - The installation location should be protected against frost and be easily accessible
 - Simplified maintenance and cleaning
 - Pressure gauge at the pressure reducing valve can be read off easily
- Provide a straight section of pipework of at least five times the nominal valve diameter after the pressure reducing valve (in accordance with EN 806-2)
 - The refilling combination has an integrated strainer - no separate strainer necessary
 - Refilling combination is protected against malfunction and corrosion damage resulting from ingress of foreign bodies, e.g. welding beads, sealing materials, metal cuttings and rust

Installation Example

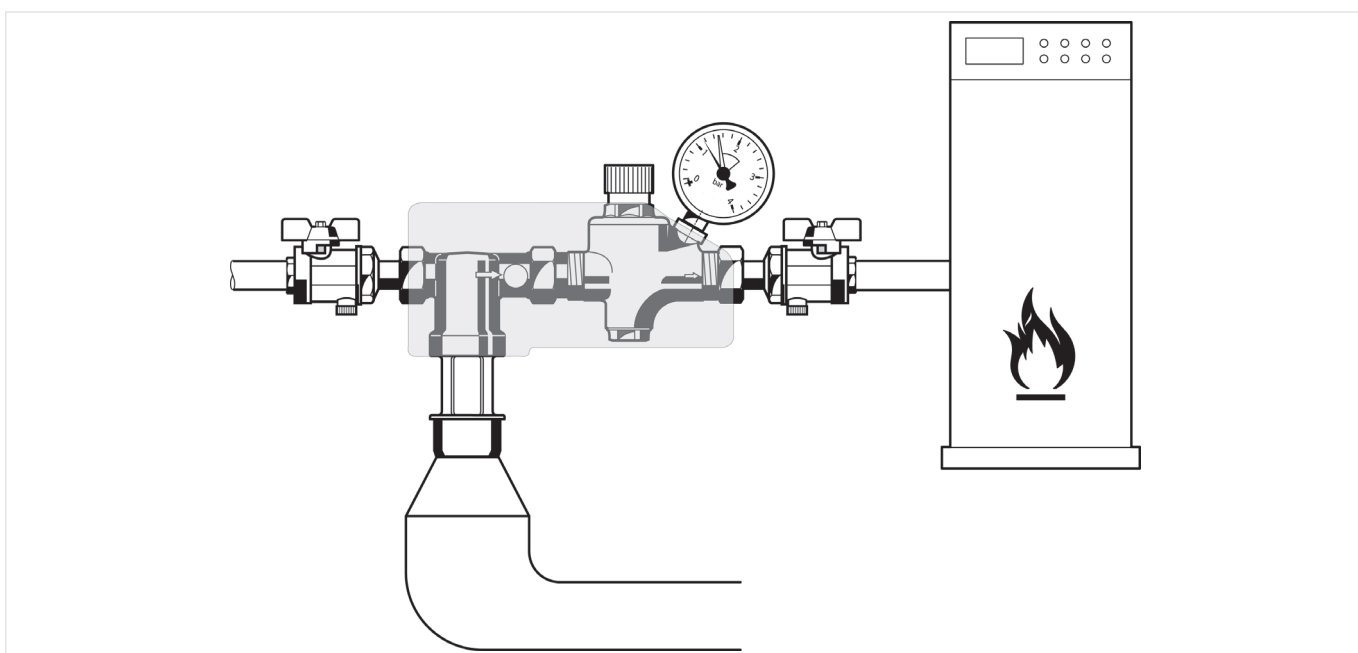
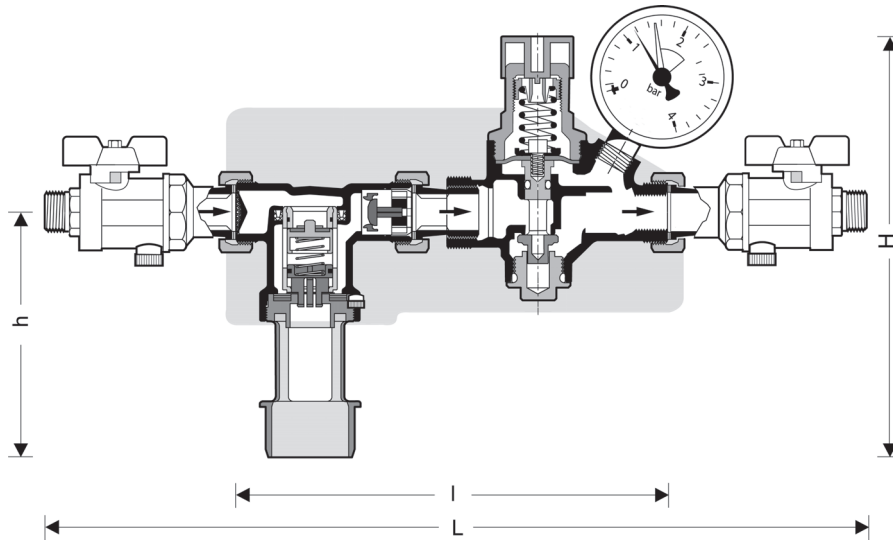

Fig. 1 Standard installation example for the refilling combination

DIMENSIONS

Overview



Parameter		Values
Connection size:	R	1/2"
Dimensions:	H	188.5
	h ₁	67.5
	h ₂	121
	L	389
	l ₁	104
	l ₂	85
	l ₃	100
	l ₄	100
Weight:	kg	1.6

Note: All dimensions in mm unless stated otherwise.

ORDERING INFORMATION

The following tables contain all the information you need to make an order of an item of your choice. When ordering, please always state the type, the ordering or the part number.

Options

The valve is available in the following sizes: 1/2"

- standard
- not available

		NK295S-1/2A
Connection type:	Standard version with threaded connection R ^{1/2} "	•



Manufactured for
and on behalf of
Pittway Sàrl, Z.A., La Pièce 4,
1180 Rolle, Switzerland
by its authorised representative
Ademco 1 GmbH

For more information
homecomfort.resideo.com/europe

Ademco 1 GmbH, Hardhofweg 40,
74821 MOSBACH, GERMANY

Phone: +49 6261 810
Fax: +49 6261 81309