

Series HLEX 4.75 - 7, HLEX 8 - 11

HOT GAS BYPASS VALVES

FIXED ORIFICE, ADJUSTABLE SUCTION PRESSURE LIMITATION

PRODUCT DATA

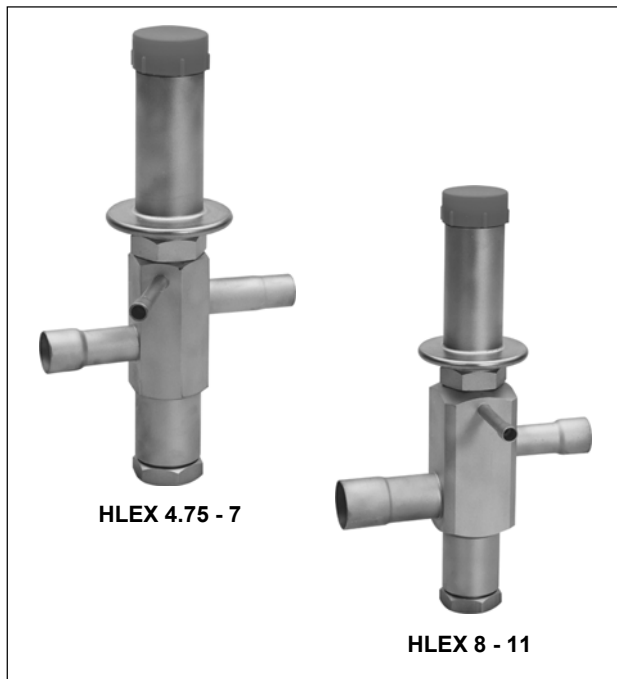

HLEX 4.75 - 7

HLEX 8 - 11

Features

- Compact design
- High performance
- Hermetic construction
- Adjustable suction pressure limitation
- Solder connections
- External pressure equalisation
- Extreme durable due to stainless steel head and stainless steel diaphragm welded using protective gas
- Balanced port construction
- Fixed orifice
- Refrigerants: all CFC, HCFC, HFC, not for ammonia

Specification

Nominal capacity	see table on page 2
Adjusting range for suction pressure limitation	1 - 9 bar(a)
Factory setting	3.7 bar(a)
Maximum pressure PS	29 bar(a)
Maximum test pressure PF	32 bar(a) (simultaneous on all connections)
Max. ambient temperature	100 °C

Installation

- The valves may be installed in any position.
- When soldering the valve, the valve body must not get warmer than 100 °C.
- Remove plastic cap during soldering
- Constructive modifications at the valve are not allowed.

Adjustment

One complete revolution of the adjusting screw effects an alternation of the suction pressure limitation by approx. 0.5 bar.

Turning clockwise	=	Higher suction pressure
Turning counterclockwise	=	Lower suction pressure

Application

Hot gas bypass valves series HLEX are used to adjust the compressor capacity to the actual evaporator capacity in a refrigerating plant.

The hot gas bypass valve can be installed in a bypass tube between the hot gas line and suction line. The suction pressure is downward limited by flowing hot gas from the high pressure to the low pressure side.

For plants in general refrigeration and for original equipment such as dehumidifiers, air driers, water coolers or ice-making machines.

Materials

Body	brass
Head	stainless steel, brass
Connection tubes	copper

Capacities

Type	Orifice size	Condensing temperature t_c (°C)	Δp_{offset} (bar)	Bypass-capacity Q_N (kW)		
				R134a	R407C	R404A
HLEX	4.75	35	0.5	0.98	1.67	1.40
			0.7	1.37	2.33	1.95
		50	0.5	1.13	1.86	1.41
			0.7	1.57	2.60	1.97
	5	35	0.5	1.29	2.18	1.83
			0.7	1.79	3.04	2.55
		50	0.5	1.47	2.43	1.84
			0.7	2.05	3.39	2.57
	6	35	0.5	1.92	3.26	2.73
			0.7	2.68	4.54	3.81
		50	0.5	2.20	3.64	2.75
			0.7	3.07	5.07	3.83
	7	35	0.5	2.35	3.98	3.34
			0.7	3.27	5.55	4.65
		50	0.5	2.69	4.44	3.36
			0.7	3.75	6.19	4.68
	8	35	0.5	2.66	4.52	3.79
			0.7	3.72	6.31	5.29
		50	0.5	3.05	5.04	3.81
			0.7	4.26	7.04	5.32
	10	35	0.5	3.29	5.57	4.67
			0.7	4.58	7.77	6.52
		50	0.5	3.76	6.22	4.70
			0.7	5.25	8.67	6.56
	11	35	0.5	4.50	7.63	6.40
			0.7	6.29	10.66	8.94
		50	0.5	5.16	8.52	6.45
			0.7	7.20	11.90	9.00

Evaporating temperature to: 0 °C; hot gas superheat Δt_{v2oh} : 25 K

Type Code / Order Information

	HLEX		5		12 mm x 16 mm
Series					
Orifice size					
Solder connections ODF (inlet x outlet)					

Dimensions and Weights

Type	Orifice size	Connections			Dimensions (mm)		Weight (kg)
		Inlet (A)	Outlet (B)	Pressure equalizer (C)	D	E	
HLEX	4.75	12 mm ODF	16 mm ODF	6 mm ODF	53	53	approx. 0.9
	5						
	6	1/2"ODF	5/8"ODF	1/4"ODF			
	7						
HLEX	8	16 mm ODF	22 mm ODF	6 mm ODF	57	65	approx. 1.3
	10						
	11	5/8"ODF	7/8"ODF	1/4"ODF			

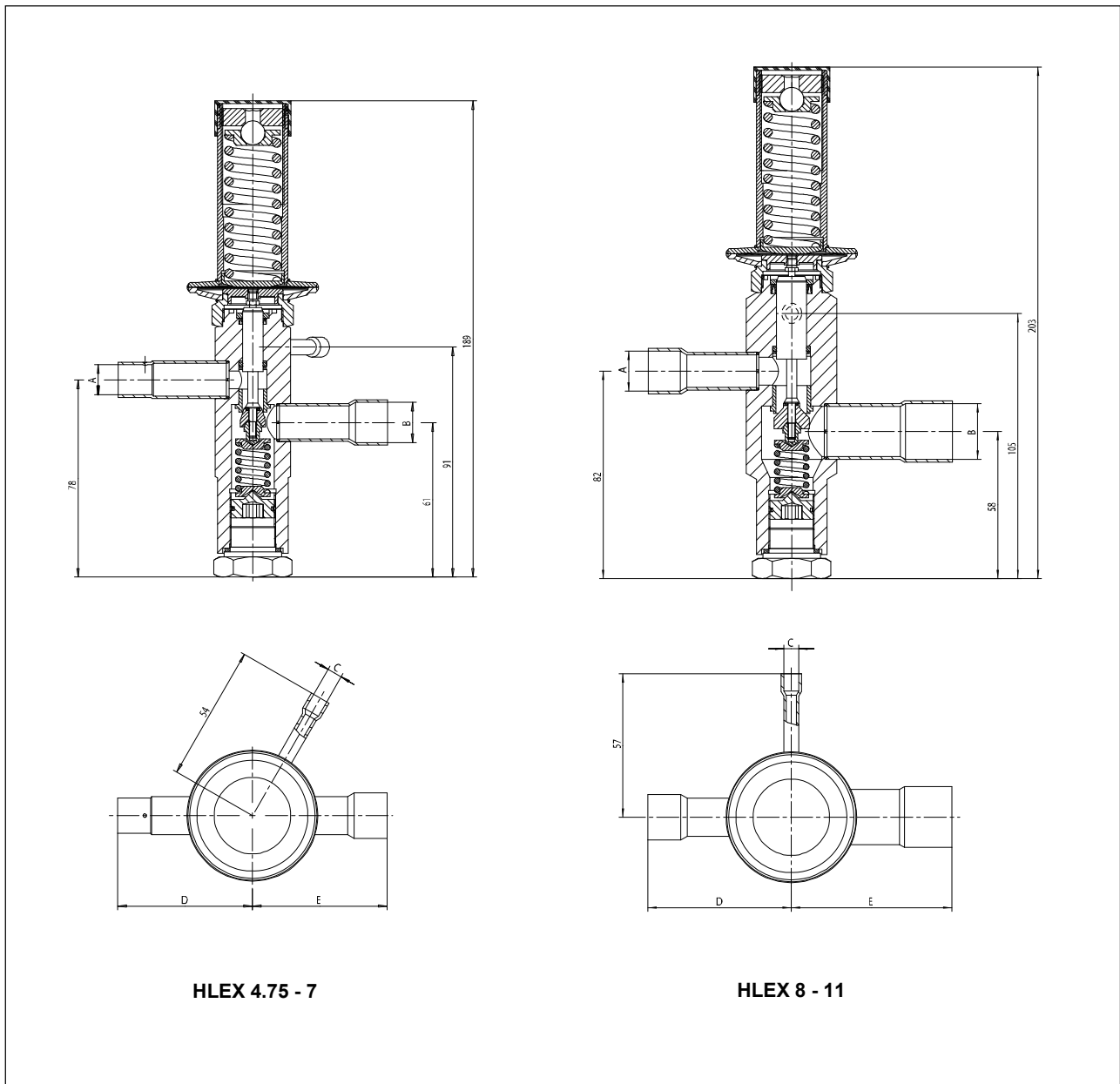

HLEX 4.75 - 7

HLEX 8 - 11

Application Samples

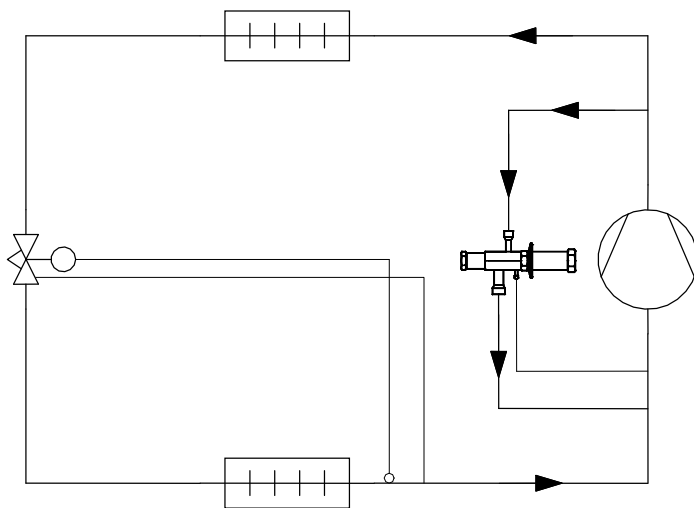

Fig. 1: hot gas bypass in the suction line

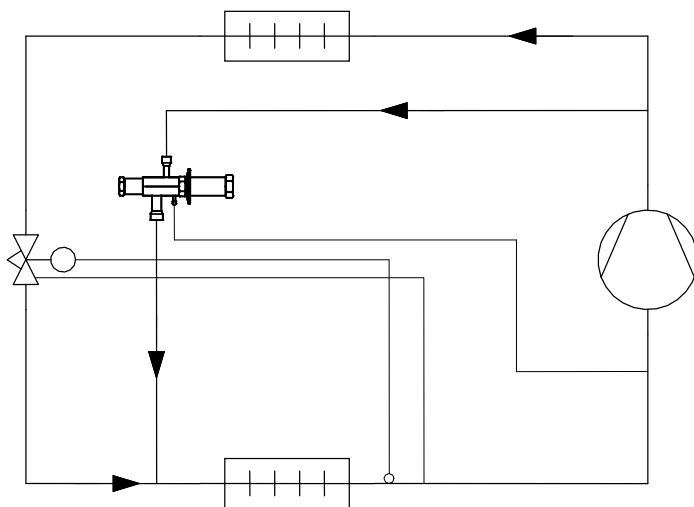

Fig. 2: hot gas bypass in the evaporator inlet

resideo

Resideo Pittway Sàrl

Z.A. La Pièce 4

1180 Rolle

Switzerland

KAT-HLEX-002