



66
66

666666

W1 Funktionskontrolle • Checking functions Contrôle de fonctions • Controllo funzioni

P = stabil
P = stable
P = stable
P = stabile

$\dot{V} = 0 \text{ m}^3/\text{h}$ oder $\dot{V} = \text{max}$
 $\dot{V} = 0 \text{ m}^3/\text{h}$ or $\dot{V} = \text{max}$
 $\dot{V} = 0 \text{ m}^3/\text{h}$ ou $\dot{V} = \text{max}$
 $\dot{V} = 0 \text{ m}^3/\text{h}$ ou $\dot{V} = \text{max}$

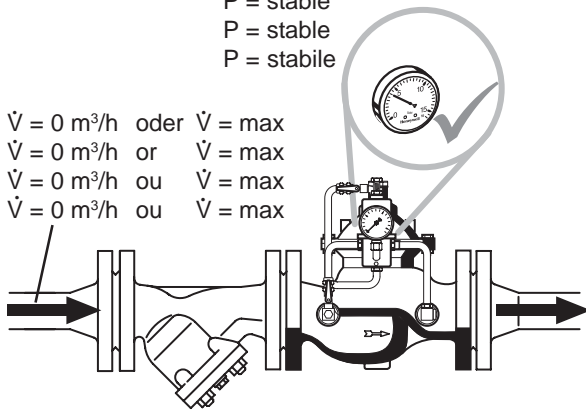

P = NICHT stabil
P = NOT stable
P = NE PAS stable
P = NON stabile

$\dot{V} = 0 \text{ m}^3/\text{h}$ oder $\dot{V} = \text{max}$
 $\dot{V} = 0 \text{ m}^3/\text{h}$ or $\dot{V} = \text{max}$
 $\dot{V} = 0 \text{ m}^3/\text{h}$ ou $\dot{V} = \text{max}$
 $\dot{V} = 0 \text{ m}^3/\text{h}$ o $\dot{V} = \text{max}$

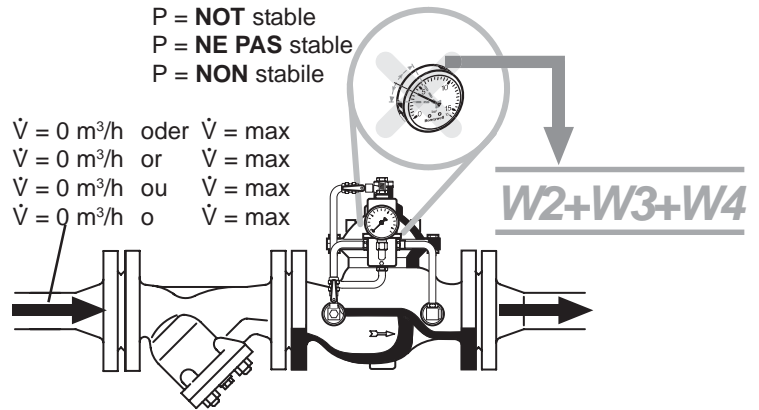

W2 Filtereinsatz reinigen • Cleaning self-flushing filter Nettoyer le filtre • Pulizia dell'inserto filtro

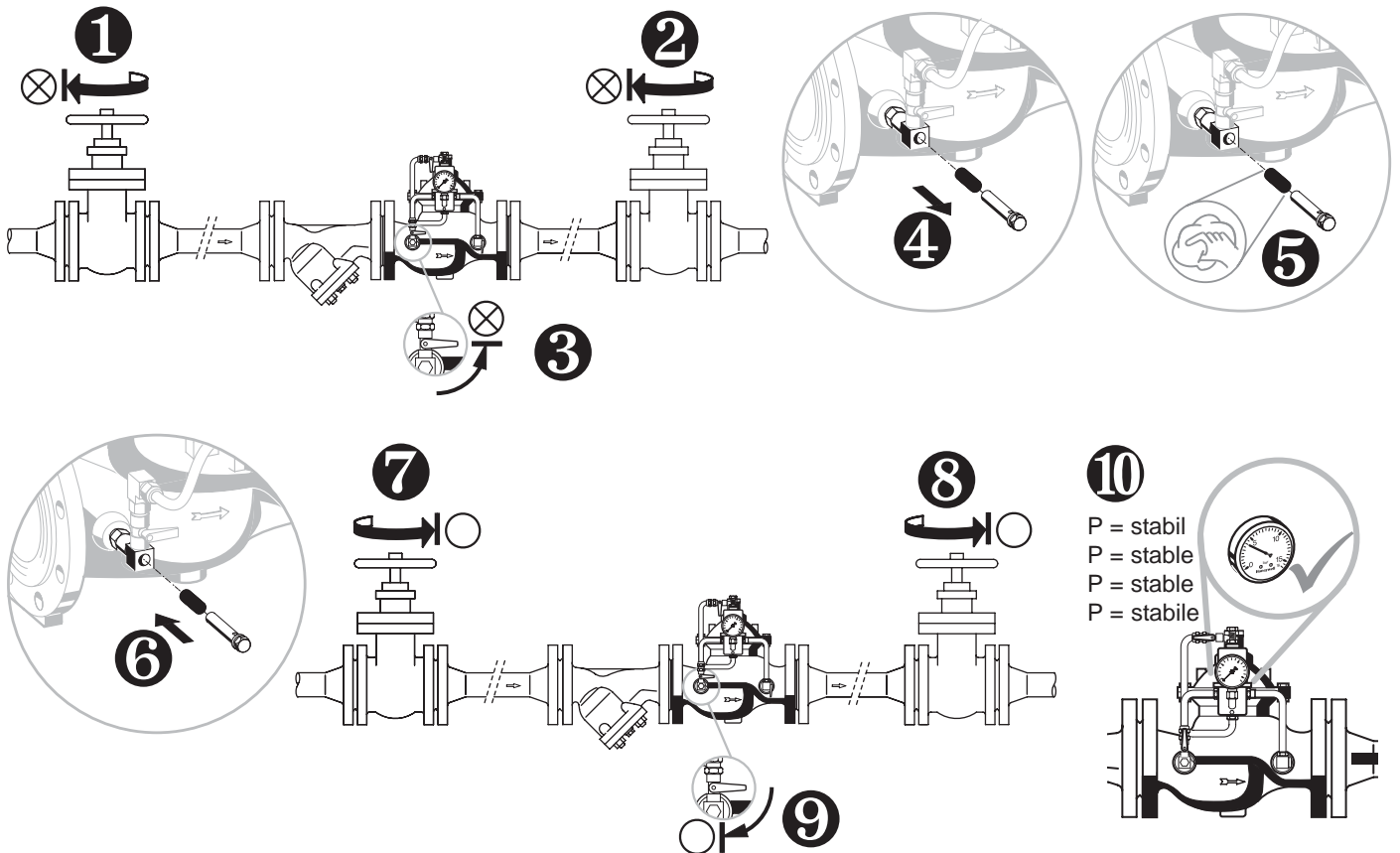

P = stabil
P = stable
P = stable
P = stabile

W3 *Pilotventil austauschen • Replace pilot valve • Changer la vanne pilote • Sostituzione della valvola pilota*

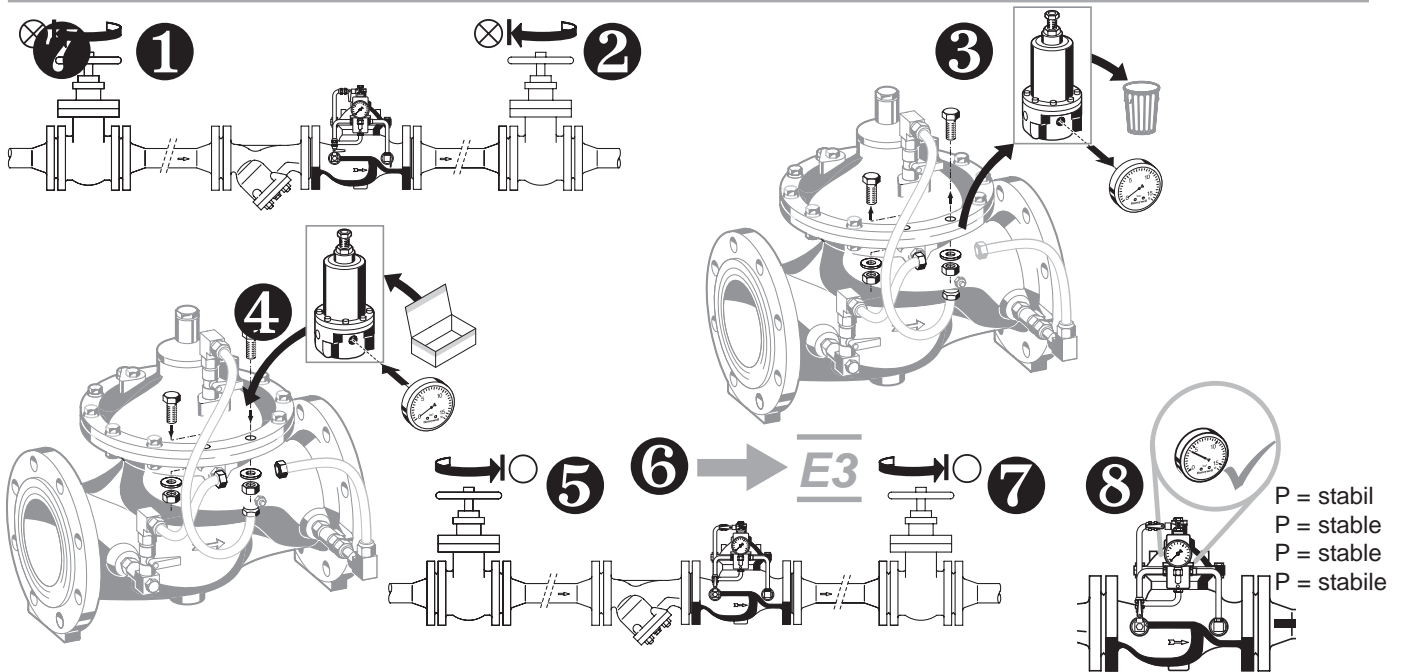

W4 *Innenteile austauschen • Replace inner Parts • Changer les pièces intérieures • Sostituzione dei componenti interni*

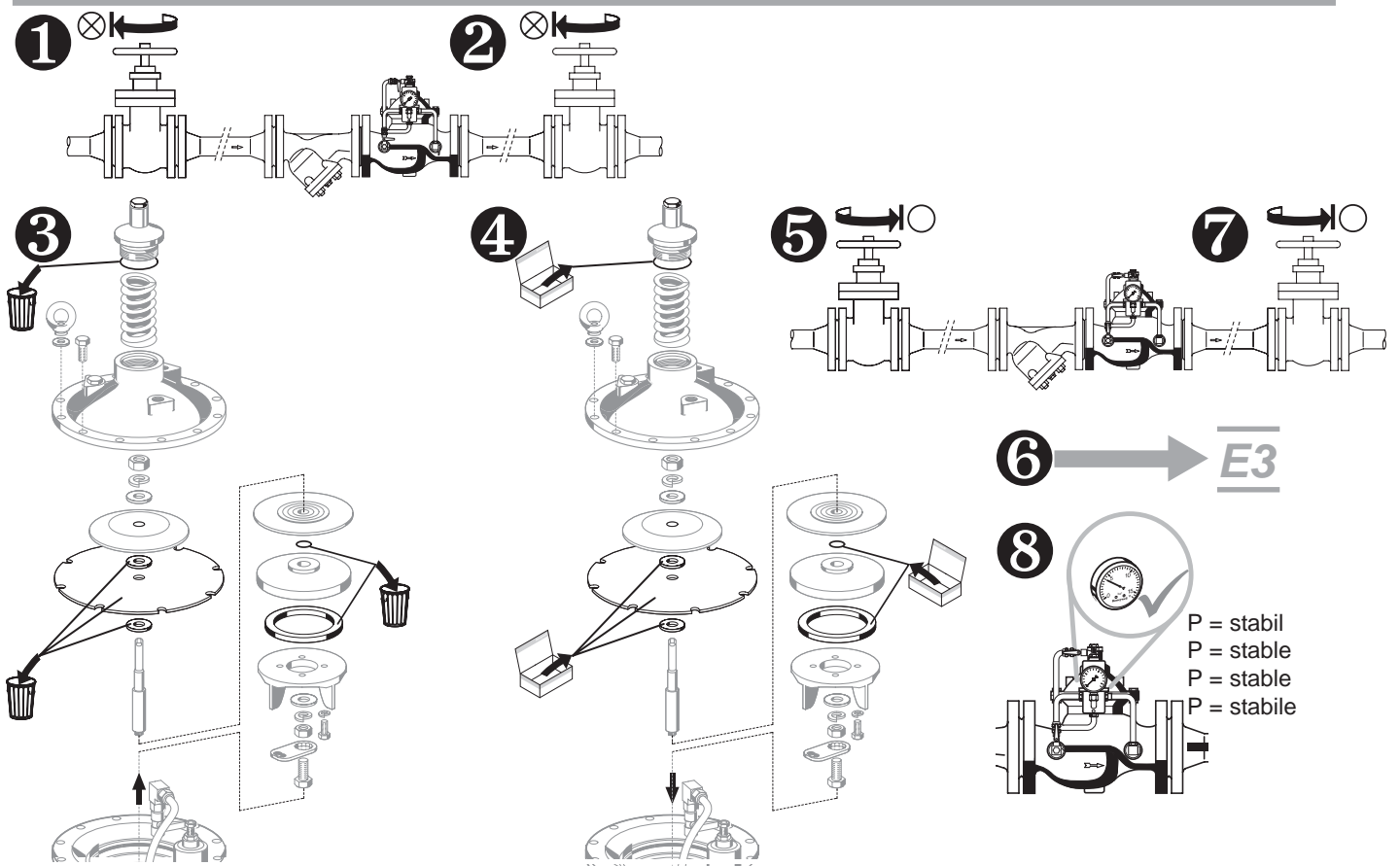

Manufactured for and on behalf of
 Pittway Sàrl, Z.A., La Pièce 4,
 1180 Rolle, Switzerland
 by its authorised representative
 Ademco 1 GmbH

For more information
homecomfort.resideo.com/europe

Ademco 1 GmbH, Hardhofweg 40,
 74821 MOSBACH, GERMANY

Phone: +49 6261 810
 Fax: +49 6261 81309